



AN ESSENTIAL PACKING GUIDE FOR EXPRESS SHIPMENTS



PACK IT RIGHT FOR THE EXPRESS JOURNEY

At DHL we do everything we can to ensure your packages are always delivered on time and in great condition.

Parcels can travel many thousands of miles through DHL's sophisticated global network to reach their destinations. Packing your shipments with appropriate materials in a right way will help ensure they arrive safely and stay intact.

Do you pack your shipments with express transportation in mind? International standards for express packaging are more stringent than other types of transportation as shipments are handled by a network of conveyors, aircraft and people.

At all times, it remains the responsibility of the sender to ensure adequate packaging is used. As a reference for DHL customers, this Packing Guide provides some general instructions and examples of good packing practices. Different shipment contents requires different level of protection, therefore this should not be perceived as a final solution suitable for all customers.

A [DHL Packing Guide](#) is also available at DHL.com to provide more specific guidelines for packing Electronic Goods, Fashion Apparel, Palletized Cargo and Temperature Sensitive Goods. Should you need further assistance, your [DHL Customer Support](#) team is only a call or email away.

Quick Tips

If you are short of time, here are some basics of good packing.

Step 1 - Assess

- Consider the weight & fragility of shipment contents
- Value of content being shipped
- Packing requirements prescribed by transportation regulations



Step 2 - Pack

- Use quality double wall boxes
- Ensure 6cm distance between shipment content and all walls of the box
- Fill all void space



Step 3 - Seal

- Use pressure sensitive tapes of at least 48mm width
- Adopt H-taping method to seal all edge and seams

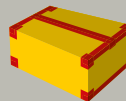

Step 4 - Label

- Apply shipment label to the top surface of your package
- Clearly display shipment label on a single surface



DISCLAIMER:

Please note that the information contained herein is general and may not apply in a specific situation, nor does it constitute an alternative to legal or other advice from an appropriately qualified professional. While reasonable care has been taken in the preparation of this document, DHL Express excludes all representations, warranties, undertakings and guarantees relating to the information contained herein to the maximum extent permitted by applicable laws. It is the responsibility of the Shipper to ensure compliance with all applicable laws, regulations and requirements at all times. All services are rendered subject to and in accordance with the [DHL Terms and Conditions](#), a copy of which is available from your local [DHL office](#).

ASSESS YOUR PACKING NEEDS

Quality packaging is key when it comes to preventing damage. Assessing your packing needs is an essential step to determine what's best for the type of goods you wish to transport.

CONSIDERATIONS THAT WILL HELP YOU DETERMINE YOUR PACKAGING REQUIREMENTS

Weight	<ul style="list-style-type: none"> Consider the strength and durability of the packaging box An appropriate box should be able to securely hold the weight of the content being shipped
Size and Shape	<ul style="list-style-type: none"> Items should not touch the outer wall of the box Odd-shaped or rounded packaging may need extra attention
Form of Contents	<ul style="list-style-type: none"> Special packaging materials and packing techniques are required for shipping liquids and powders
Value of Contents	<ul style="list-style-type: none"> Extra cushioning and protection may be required for high value goods
Fragility	<ul style="list-style-type: none"> Extra cushioning and protection are required for fragile items Apply special handling label
Final Use	<ul style="list-style-type: none"> Does the box need to be retail ready? Do you want to avoid any markings on the box?
Regulations	<ul style="list-style-type: none"> Some regulated items may require specialist packaging



INFLUENCING FACTORS



Weight



Humidity



Cost

...

and more

Dangerous Goods

Did you know that food flavoring, perfumes, chemicals and electronic equipment can be classified as dangerous goods?

Contact our Restricted Commodities team via

for specialist advice, and to learn about specific regulatory requirements if you would like to ship dangerous goods with DHL Express.

Restricted and Prohibited Commodities

Some items are prohibited for transportation with DHL Express and are classified as either Prohibited or Restricted commodities.

Please refer to > [DHL.com](https://www.dhl.com) for more information, or contact your local

CHOOSE SUITABLE MATERIALS

Good quality packaging is critical to protecting your shipment during transportation. DHL provides a range of packaging supplies that are tried and tested. However, if you prefer to use your own materials, the following provides some general guidelines.

Since this guide is designed for general use across a wide variety of products, we recommend that you also refer to packaging standards within your industry.

EXTERNAL PACKING MATERIALS

Parcel	
Material	<ul style="list-style-type: none"> Always use high quality corrugated cardboard boxes for parcels. For fragile or heavy items, double-wall or tri-wall constructions are recommended. Avoid reusing old boxes as they may have lost some of their rigidity.
Strength	<ul style="list-style-type: none"> Look out for the manufacturer stamp which tells you information about the construction type and strength of a box. Ask your box supplier for more information as required. Refer to the box specifications below to select suitable packaging for the weight of your shipment.
Size	<ul style="list-style-type: none"> Under-filled boxes may collapse and over-filled boxes may burst. Prevent this by choosing a box with the right size for the content being shipped.
Flyer Bag	
Strength	<ul style="list-style-type: none"> To avoid splits or tears, the tensile (stretch) and seam (seal glue) strength of the flyer bag should meet the recommended standards outlined below. DHL Flyer Bags have a minimum elongation (stretch) of 35cm prior to failure and can hold 30% more weight at the seam.



CHOOSE A BOX OR FLYER APPROPRIATE FOR THE WEIGHT OF YOUR SHIPMENT

Box Specifications				Flyer Bag Specifications			
Parcel Weight	Construction	Bursting Test (pounds-per-square-inch)	Edge Crush Test (pounds-per-square-inch)	Document Weight	Construction	Seam Strength	Tensile Strength (pounds-per-square-inch)
Up to 5kg	Single Wall	155	34	Up to 4kg	Polythene (60µm)	4 kg	MD/TD 32.5Mpa & 400% elongation at break
5-10kg	Single Wall	160-200	34				
10-15kg	Double Wall	250-300	55				
15-20kg	Double Wall	250-300	55				
20-25kg	Double Wall	250-300	55				
25-30kg	Double Wall	350	55				
>30kg	Specialist Packaging Method						







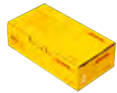

Remarks:

- Burst-Test** (aka Mullen Test) is the force of pounds per square inch required to rupture or burst the side of a corrugated box. The result indicates the box's ability to withstand external or internal forces, and how the box will contain its contents during rough handling.
- Edge-Crush-Test** (ECT) measures the stacking strength of corrugated cardboard boxes or fiberboard. Determining a finished box's compression-strength is defined by the amount of force that is needed to crush the cardboard by standing it on its edge.
- Seam Strength** refers to the load requires to break a seam.
- Tensile Strength** is the maximum stress that a material can withstand while being stretched or pulled before failing or breaking.

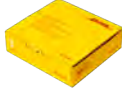
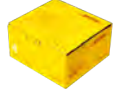
DHL PACKAGING RANGE





A range of DHL packaging supplies are made available for DHL account holders to
 or by calling local
 are also available at
 shipping with us.
 . Limited quantities
 for use by non-account holders

EXTERNAL PACKING MATERIALS





Boxes					
Box Type		Weight Limit	Size (mm)	Bursting Test (pounds-per-square-inch)	Edge Crush Test (pounds-per-square-inch)
Box 2		1 kg	337 x 182 x 100	155	34
Box 2 Pizza		1 kg	330 x 310 x 43		
Box 3		2 kg	336 x 320 x 52	160	34
Box 4		5 kg	337 x 322 x 180	160	34
Box 5		10 kg	337 x 322 x 345	280	52
Box 6		15 kg	417 x 359 x 369	280	52
Box 7		20 kg	481 x 404 x 389	280	52
Box 8		25 kg	541 x 444 x 409	280	52
Express Tube Tube 3 Tube 4			475 x 155 x 134 976 x 176 x 152		

Remarks: Dimensions mentioned above are for reference only. Packaging range may vary in different countries. Please refer to or contact in your country for options available.



Envelopes and Flyers				
Flyer Type	Weight Limit	Size (mm)	Seam Strength	Tensile Strength
Envelope 0 		190 x 252	—	—
Envelope 1 	0,5 kg	350 x 275	—	—
Standard Flyer 	2 kg	400 x 300	4 kg	MD/TD 32.5Mpa & 400% elongation at break
Large Flyer 	3 kg	475 x 375	4 kg	MD/TD 32.5Mpa & 400% elongation at break



Wine packaging		
Box Type	Weight Limit	Size (cm)
Wine insert 		14 x 14 x 37
Millésime 2 	1 kg	14 x 14 x 38
Millésime 3 	2 kg	27 x 14 x 38
Millésime 4 	5 kg	40 x 14 x 38
Millésime 5 	10 kg	41 x 27 x 38

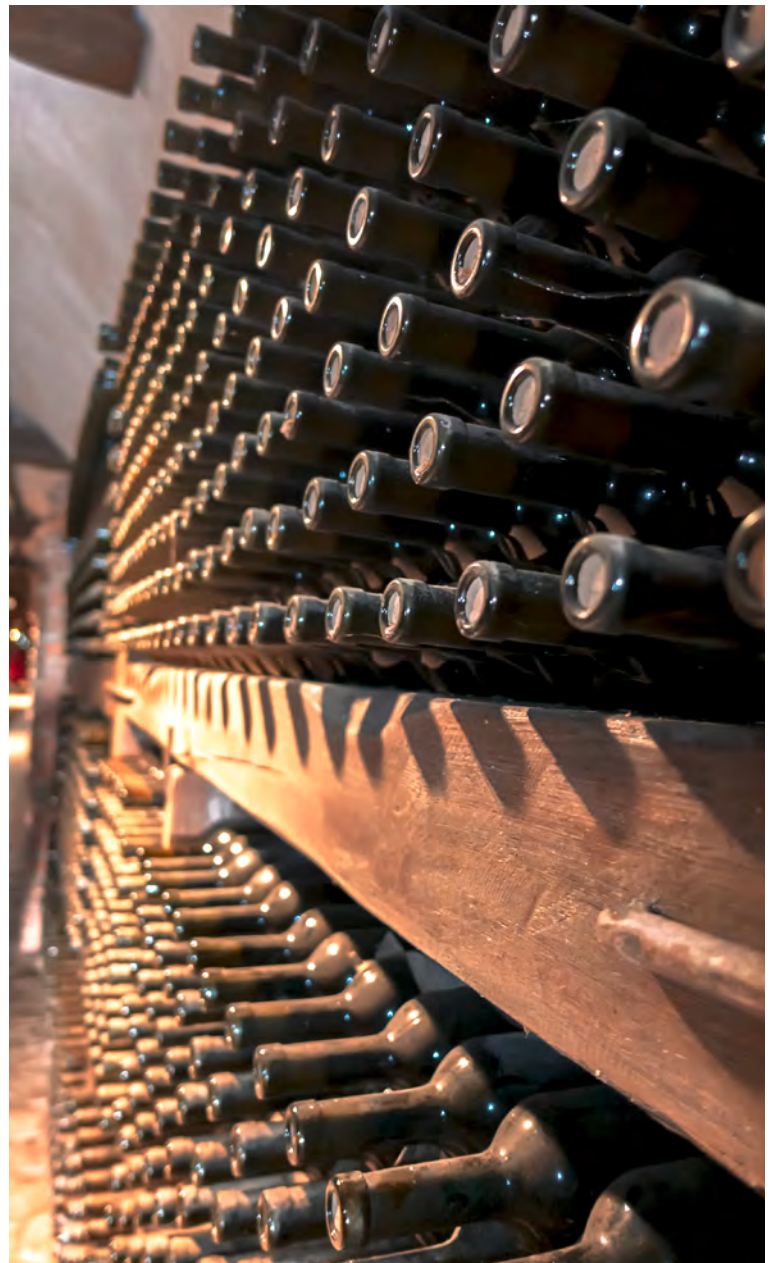

INTERNAL PACKAGING MATERIALS

Bubble wrap, airbags, cardboard and foam peanuts/pellets are all commonly used as packaging material. All have different qualities and it is important to use them appropriately.

Following the below table will help you decide what material is suitable for your needs.

Note that while bubble wrap offers some void fill properties, it is more effective to use more suitable materials when trying to fill larger spaces.



Type of Material	Packaging Function				
	Cushioning	Void Fill	Protection	Divider	Other Function
Bubble Wrap	✓	✓	✓		
Small Cell ¼ inch Suitable for lightweight items					Interleaving
Large Cell ½ inch Suitable for medium weight products					Blocking
Foam Wrap	✓	✓	✓		
Foam peanuts/pellets	✓	✓		✓	
Air Bags		✓			
Crumpled Paper		✓	✓		
Corrugated Inserts		✓	✓	✓	
Shredded Cardboard		✓	✓	✓	Shock absorption

APPLY PACKING TECHNIQUES

Following the first two sections of this guide you will now have assessed your packing needs and prepared suitable packaging materials for your shipment.

Before introducing packing methods, here are some important principles applicable for packing your shipment contents.

LEAVE NO EMPTY SPACE

- It is important to completely fill empty space within the box to avoid contents moving during transit which can cause damage to both contents and box.
- Place void filler on the base of the box then around the item you are shipping. Ensure there are no gaps or movement.
- When choosing void filling materials, always ensure that they would provide sufficient support for the weight of the shipment contents. Some materials may sink or deflate under the weight of the content which may eventually leave empty space inside the box.

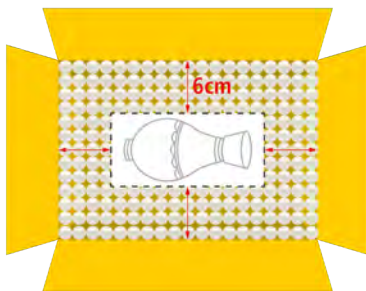

6CM DISTANCE

- Always place items being shipped in the center of the box with at least 6cm of separation from any external walls or corners.
- Take this into consideration when determining the size of box relative to the size of the contents.

WRAP ITEMS INDIVIDUALLY AND USE DIVIDERS

- When shipping multiple items in a single package, always wrap each item individually and separate with corrugated inserts or other divider materials as appropriate.
- Dividers are helpful to avoid damage caused by individual items making contact during transit, especially when items are stacked.
- Small or loose items should be placed in an inner container or plastic bag to avoid the items separating during transportation.



PACKING METHODS

The most suitable packing method to use will depend upon the assessment you have carried out in section 1.

The main packing methods we recommend are outlined below but if you need any assistance, please contact your local

BASIC PACKING METHOD

Protection Level: ■■■■

Suitable for most non-fragile articles (e.g. printed matters, machinery parts, metal parts etc.)

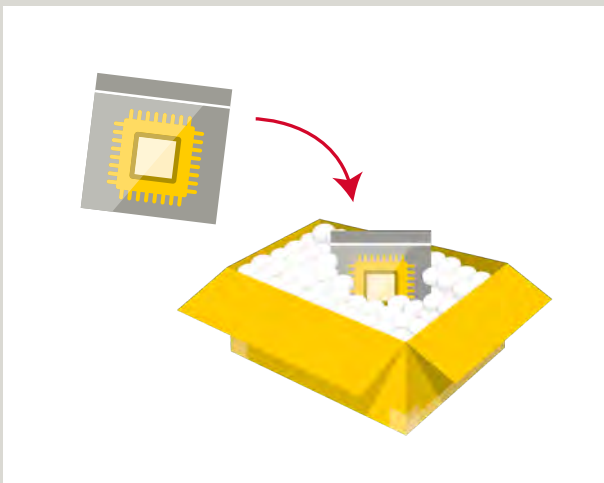

- We recommend preparing a double wall box, but if using single wall, ensure your box has suitable strength for the weight of its contents.
- Items that may be affected by moisture and staining should be placed into a strong plastic bag or container for extra protection.
- Ensure your items are placed centrally in the box with at least 6cm of separation from any of the external walls and corners.
- If shipping multiple items within a single box, ensure each one is wrapped individually and well separated from one another.
- Fill any void space to prevent items moving within the box during transport.

BOX-IN-BOX METHOD

Protection Level: ■■■■

The box-in-box method utilizes a second outer box to offer additional protection. It is useful for the transportation of more fragile items or where the inner box will be used for retail purposes.

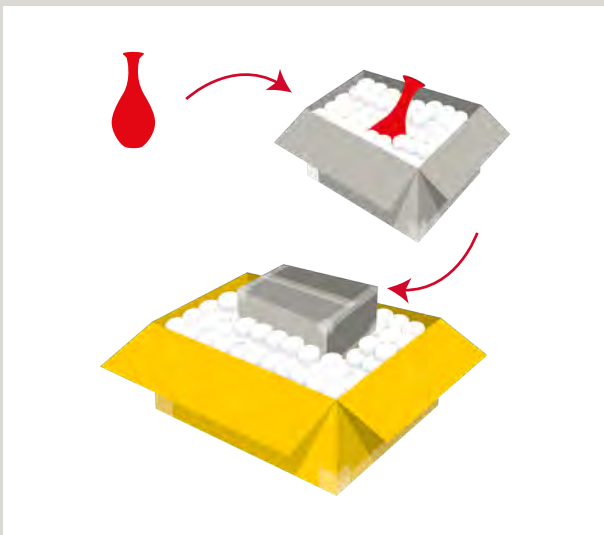

- Both an outer and inner box will need to be prepared.
- We recommend using the original manufacturer's packaging as the inner box where possible. Alternatively, the inner box should be packed using the basic packing method outlined above.
- The outer box should be at least 14cm larger in all dimensions than the inner box to provide sufficient overpack protection. We recommend a double wall box but if using single wall, ensure your box has suitable strength for the weight of its contents.
- Place approximately 6cm of void fill in the base of the outer box before centrally placing the inner box inside.
- Restrict any movement of the inner box by filling void space on all sides before sealing the outer box ready for transportation.

LIQUIDS AND POWDERS

Many common household liquids and powders are classified as dangerous goods and are carefully regulated for transport on aircraft. If you are not a registered dangerous goods shipper, DHL may not be able to transport your items. Contact your local for more information.

If the items are not classed as dangerous goods and subject to more stringent packaging requirements, the following steps will help prevent loss or damage during transport.

Liquids	Semi-liquids, greasy or strong smelling substances	Powders and fine grains
		
<p>Ensure liquids are contained in leak-free containers and protected with strong internal material such as styrofoam. Seal in a plastic bag before putting into a strong double wall box.</p>	<p>Seal semi-liquids, greasy or strong-smelling substances with adhesive tape. Wrap in grease-resistant paper before putting into a strong double wall box.</p>	<p>Powders and fine grains should be placed in strong plastic bags, securely sealed and then packed in a rigid fiberboard box.</p>



REMINDER

If your shipment meets the requirements of **“Special Provision”** listed under the corresponding entry in Column M of the IATA Dangerous Goods Regulations, DHL Express requires shippers to declare the shipment as **“Not restricted as per special provision X.”** on the waybill and/or invoice description.



SECURITY CONDITIONS FOR WINE & SPIRITS PACKAGING

For your Wine & Spirits shipments, we offer a range of tested and approved impact resistant packaging. If you wish to use your own packaging, you must ensure that the following conditions are fulfilled to guarantee the best protection. They apply whether the goods are insured or not.

These safety conditions will help you to prevent damage that may occur during transport.

Security condition

**Condition 1 :**

The packaging must have at least double or triple flute protection.

**Condition 2 :**

The bottle must be in an insert. A splitter will not be sufficient in shipment.

**Condition 3 :**



In this insert, the bottle must be held at the neck and bottom of the bottle.



DOCUMENTS

Whether you are shipping bills of lading, the contract for your new house, or transferring case files, DHL has the packaging to suit your needs. Our document shipping advice can be split depending on the weight, size and quantity of documents you are shipping.

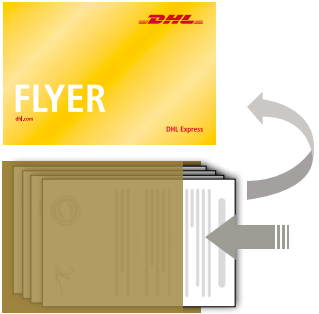

Single documents	Multiple documents (less than 2kg)	Multiple documents (more than 2kg)
		
<ul style="list-style-type: none"> ■ Use the DHL Envelope for shipping documents of up to 24 pages or 500g of weight. ■ The cardboard design offers basic protection against bending and creasing. ■ Seal the envelope and place in a DHL Flyer Bag for added protection against moisture and stains. 	<ul style="list-style-type: none"> ■ The DHL Flyer Bag is suitable for carrying up to 2kg of documents. ■ Secure the documents in a suitable envelope, sleeve or folder before placing in a DHL Flyer Bag. ■ Include adequate contact information on each envelope to enable contact if necessary. ■ For added protection, place a sturdy piece of card within the DHL Flyer Bag to reduce movement during transit. 	<ul style="list-style-type: none"> ■ Prepare a sturdy box for carrying documents weighing more than 2kg. ■ DO NOT use archive or copy paper boxes as they are not designed for Express Transport. ■ Secure the documents in a suitable envelope, sleeve or folder with adequate contact information to enable contact if necessary. ■ Always fill up void space to prevent any movement of the documents inside the box during transit.

SEAL AND LABEL SHIPMENT

A good seal helps to protect your package during transit. Both the adhesive tapes you choose and how you seal the shipment makes a difference in protecting your shipment contents from being exposed or damaged during transit.



USE PRESSURE SENSITIVE TAPES

DHL recommends the following pressure sensitive tapes for their strength and durability:

- Polypropylene tape (brown plastic tape)
- Vinyl adhesive tape (electrical tape)
- Fiber-reinforced paper tape (duct tape)



AVOID USING...

Kraft Paper Tape



Cellophane Tape



Masking Tape



String / Rope



H-TAPING

Ensure all seams are sealed using the H-taping method:

- Apply 1 strip of tape along the center seam
- Apply 2 strips of tape across both edge seams
- Apply more strips of tapes for heavier shipments
- Repeat the H-taping so that both the box's top and bottom seams are sealed

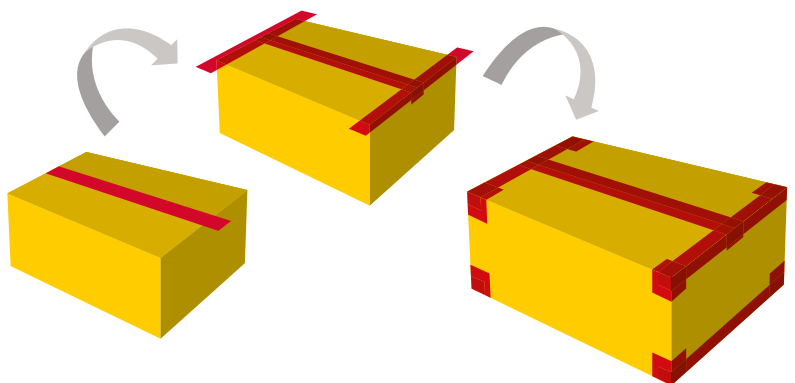

Not endorsed for individual parcel weighing <30kg

STRAPPING

DHL Express does not endorse the use of strapping or banding for items less than 30kg in weight as it can damage both our network machinery and the package itself.

Suitable packaging should always be capable of carrying the weight of the items without the need for strapping.

When shipping pieces weighing more than 30kg, strapping is an ideal way to strengthen your shipment when applied correctly.

SPECIAL HANDLING LABEL*

Although DHL cannot guarantee maintaining the stable orientation of shipments during transport, our teams actively look for visible special handling instructions. Proper use of handling instruction labels can help ensure the appropriate transport, handling and storage of your shipment during transit. Here are examples of commonly used labels:



This Way Up

The upward arrows show the direction that the package must be transported handled and stored.



Fragile, Handle with Care

The package must be handled carefully.



Keep Dry

The package must be protected from excessive humidity and be stored under cover.

*Any special handling label must be applied by the shipper prior to courier collection.

APPLYING SHIPMENT LABEL

Displaying the shipment labels clearly is important in ensuring that your shipment moves swiftly through DHL's network. Below are a few key points to note:

- Fix the shipment label securely on the top surface of the shipment box. This will help us keep your shipment in an upright position as much as possible during transit!
- Ensure the label is wholly visible on one surface and that the label does not cover any seams.
- Do not let other labels, tapes or paperwork cover the shipment label.
- We never recommend using an old box but if you do, ensure all outdated shipment labels are removed prior to use.
- Placing a spare label inside the package will help us identify your shipment if the original label becomes detached or damaged.
- If you need to apply other labels on your shipment, please avoid placing them on the same surface as the shipment label.
- Use a plastic self-adhesive clear window pouch to hold any loose documents that are required to be placed outside of the box.



Did you know?

You can create your shipment label within a few clicks with [DHL's online shipping label creation tool](#). Completing an electronic waybill is easy as you will be guided through the process to avoid missing any information required for swift and accurate delivery of your shipment.

To check out which electronic shipping solution best fits your needs of managing international express shipments effectively, please visit [DHL's eWaybill solution](#).

HELP REDUCE YOUR CARBON FOOTPRINT. GET PACKAGING RIGHT THE FIRST TIME.

Damaged items lead to additional manufacturing and transportation. Protecting your shipment with appropriate packaging is an effective way of reducing carbon footprints.

DHL Express – Excellence. Simply delivered.
[dhl.com](https://www.dhl.com)

